

THUNDERING MANTIS

Build Document last updated february 2018

for PCB version 1.0

The Thundering Mantis Fuzz is a glitchy and gated octave fuzz in a simple to use one-knob format. It has a mix of one octave down and one octave up, perfect for playing synthy leads, without having to tweak so many knobs. Easy build for beginners.

This is a gated circuit that works best with high output pickups. If you are using single coils and need more sustain, try a boost or compressor in front. To tighten up the tracking, use your neck pickup with the tone rolled off.

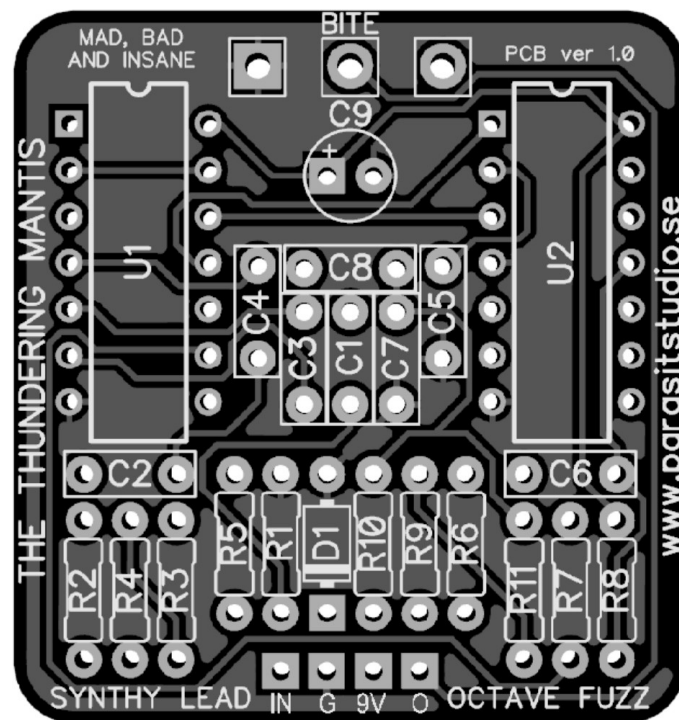

General builds tips

- Solder the low profile components first, from short to tall height. Recommended order: resistors, diodes, IC socket, film-caps, electrolytics, pots and switches
- CMOS chips are very sensitive to static charges and can be easily damaged. It's a good idea to wear a anti-static wristband or at least avoid wearing a wool jumper and petting your cat/dog while building...
- Always use sockets for IC chips and transistors to avoid heating them directly. It also makes it much easier to swap them out if needed.
- Pay special attention to the orientation of the diodes and electrolytics.
- All PCB's are designed for 16mm Alpha PCB mount angeled pots. You could also use solder lug type and just tack some "legs" with short pieces of wire to each pot to mimic a PCB mount type.
- The square pad represents pin 1 of the pot.
- The potentiometer is meant to be mounted on the backside (the solder side) of the PCB and soldered from the front side (component side).
- Cover up the backside of the pot, with a pot cover or insulation tape, so that it doesn't short out against the PCB.

Bill Of Materials (BOM)

Capacitors		Resistors		IC's	
C1	100nF	R1	1M	U1	CD4069UBE
C2	100nF	R2	1M	U2	CD4007UBE
C3	2.2nF	R3	1M	Potentiometer	
C4	4.7nF	R4	47K		
C5	1nF	R5	1M	VOLUME	B100K
C6	10nF	R6	10K	Diodes	
C7	2.2nF	R7	100K		
C8	100nF	R8	220K	D1	1N4001
C9	47uF	R9	2.2M	on/off LED x1	
		R10	100K		
		R11	4.7K		
		CLR*	4.7K-22K		

- * = Current limiting resistor for the LED. This needs to be wired offboard together with the bypass LED. Choose the appropriate value for the type of LED you are using. A 4.7K resistor is usually a good value for a regular diffused LED and 15K resistor for a superbright clear LED.
- **Other things that are not included in the BOM but good to have: enclosure, input and output jacks, LED Bezel, DC jack, 3PDT switch and a knob.**

Wiring

For more info on how to wire up the stompswitch, jacks ect, please visit the Parasit Studio website and download the PDF called "offboard wiring". You can find it here:

<http://www.parasitstudio.se/build-docs.html>

Drilling template (1590B)

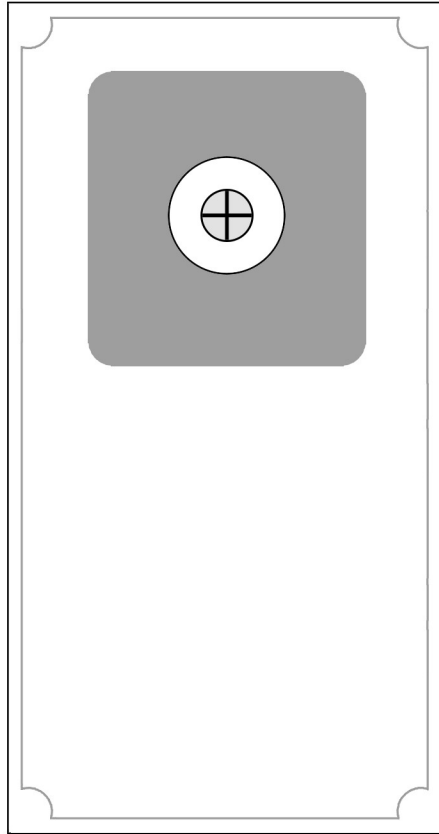

- Use at your own risk! This template is approximate.
- Make sure your printer isn't doing any scaling / is set to 100% print size.
- Drill footswitch, DC jack, LED socket and input/output jacks to your own preference.
- **Measure and confirm before drilling!**

Schematic

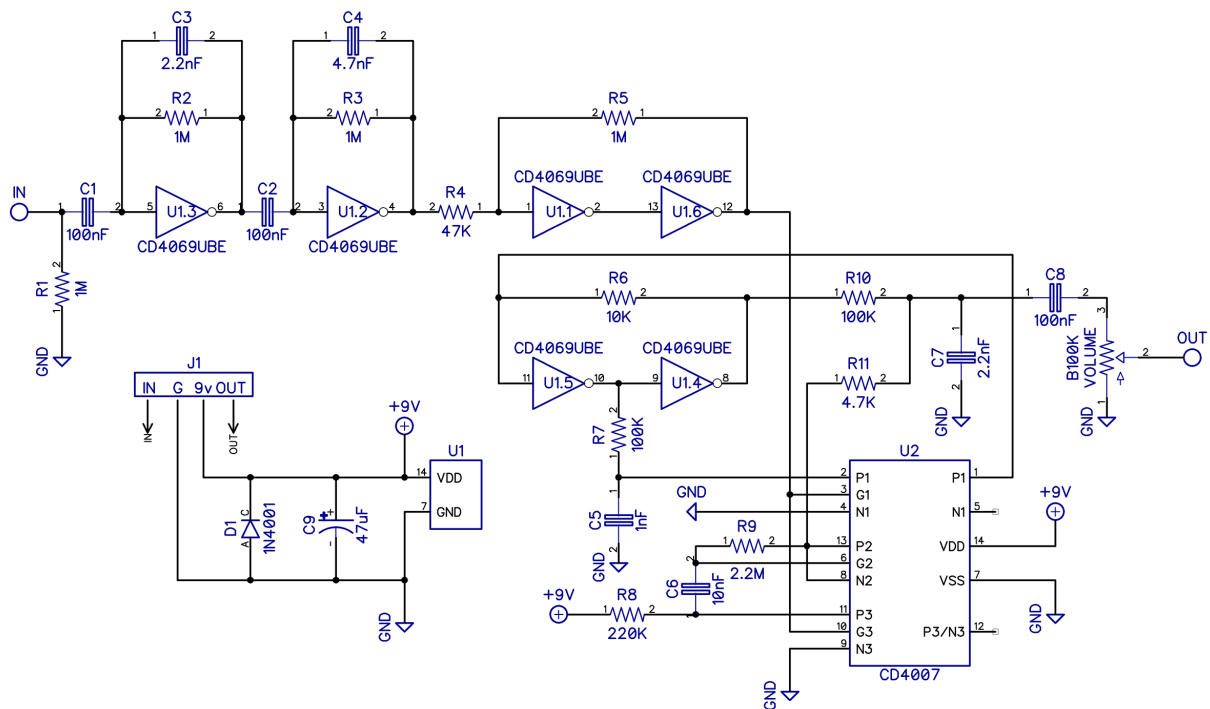

Troubleshooting

There's always a chance of running into trouble. To minimize error, follow the BOM and general building tips carefully. Take your time and don't rush. Take a break now and then. Use good solder, and it helps to have a decent soldering station instead of a cheap iron.

If you are still having trouble, please visit the madbean forum Parasit Studio subforum section and ask for help there.

<http://www.madbeanpedals.com/forum/index.php?board=84.0>

If you have bought the Musikding kit and have received a faulty or missing component, please contact musikding directly.

Terms of use

PCB's from Parasit Studio are intended for DIY use only. Commercial resale is not allowed. It's meant for personal use, which means that it's not allowed to build a lot of pedals and sell them for profit to strangers using public forums and craigslist ads. However, it's totally ok to build a few pedals and sell to your friends and bandmates. After all, that's what this hobby is about. DIY or DIE!

www.parasitstudio.se
parasitstudio@gmail.com