

# SONIC REDUCER BITCRUSHER

Build Document last updated june 2017  
for PCB version 2.0

The Sonic Reducer bitcrusher is a sample rate reducer / aliaser that uses sample and hold to take "snapshots" of your signal. It basically works as a crude analog to digital converter. A pulse oscillator determines at which frequency these samples are taken. The resolution pot controls the pulsewidth of the oscillator - wider pulse lets more clean signal though. Happy playing!

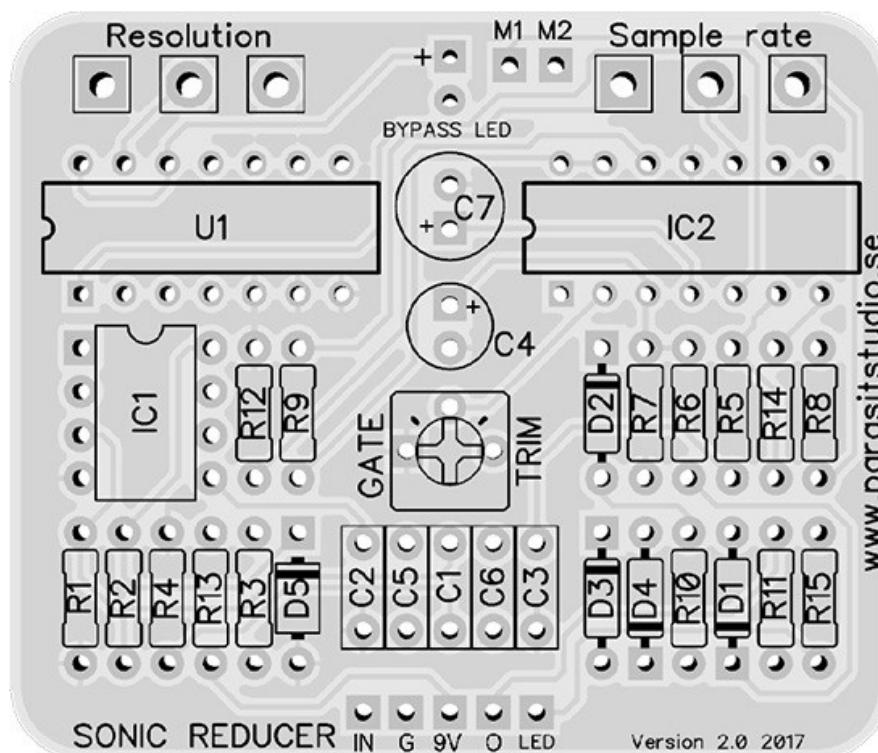

## Changelog version 2.0

- Input stage redesigned. It's now possible to use lower noise TL072 and TL074 without the risk of oscillation.
- JET removed. No longer a need for a hard to source JFET or SMD adapter.
- Range extended – more crush!
- Controls reversed.
- Board-mounted bypass LED.

### General builds tips

- Solder the low profile components first, from short to tall. Recommended order: resistors, diodes, IC socket, film-caps, electrolytics, pots.
- Always use sockets for IC chips and transistors to avoid heating them directly. It also makes it much easier to swap them out if needed. *Note: The transistor socket for this PCB doesn't actually fit a socket. Just be careful when soldering.*
- Pay special attention to the orientation of the diodes and electrolytics.
- This PCB is designed for board mounted angled pots, but if you want to use regular solderlug-pots, the square holes represents pin 1 of the pot.
- Mount the pots on the bottom (solder side) of the board, and solder it on the top (component side).

### Wiring

For more info on how to wire up the stompswitch, jacks ect, please visit the Parasit Studio website and download the PDF called "offboard wiring". You can find it here:

<http://www.parasitstudio.se/build-docs.html>

## Sonic Reducer Bill of Materials (BOM)

<b>Capacitors</b>		<b>Resistors</b>		<b>IC's</b>		
C1	100nF	R1	2.2M	IC1	TL072	
C2	47nF	R2	2.2M	IC2	TL074	
C3	100nF	R3	1M	U1	CD4066BE	
C4	10uF	R4	1M	<b>Potentiometers</b>		
C5	22nF	R5	1K			
C6	100nF	R6	100R			
C7	100uF	R7	2.2K			
<b>Diodes</b>		R8	15K	SAMPLE RATE	C1M	
		R9	33K	RESOLUTION	B50K	
		R10	4.7K	GATE (TRIM)	100K	
		D1	1N4148	R11	100K	
		D2	1N4148	R12	470K	
		D3	1N4148	R13	470K	
		D4	1N4148	R14	470K	
		D5	1N5817	R15*	15K	
1x LED						

- The Gate trimmer sets the threshold for the oscillator in relation to the input signal. Adjust until the oscillator only turns on when playing.
- \* Current Limiting Resistor for your bypass LED. Use the appropriate value for your LED type. I suggest using a 4.7K resistor for a normal diffused LED, or a 15K resistor for a clear superbright LED.
- Mount the bypass LED in the two top pads that says "bypass led". There's a LED symbol on the bottom side. Long LED leg goes to the + pad. Solder the LED from the component side last after you have placed the PCB inside your enclosure.
- **Not included in the BOM but good to have: enclosure, input and output jacks, LED bezel, DC jack, 3PDT switch and knobs.**

## Drilling template



- Use at your own risk! This template is approximate.
- Make sure your printer isn't doing any scaling / is set to 100% print size.
- Drill footswitch, LED's, DC jack and input/output jacks to your own preference.
- **Measure and confirm before drilling!**

# Schematic

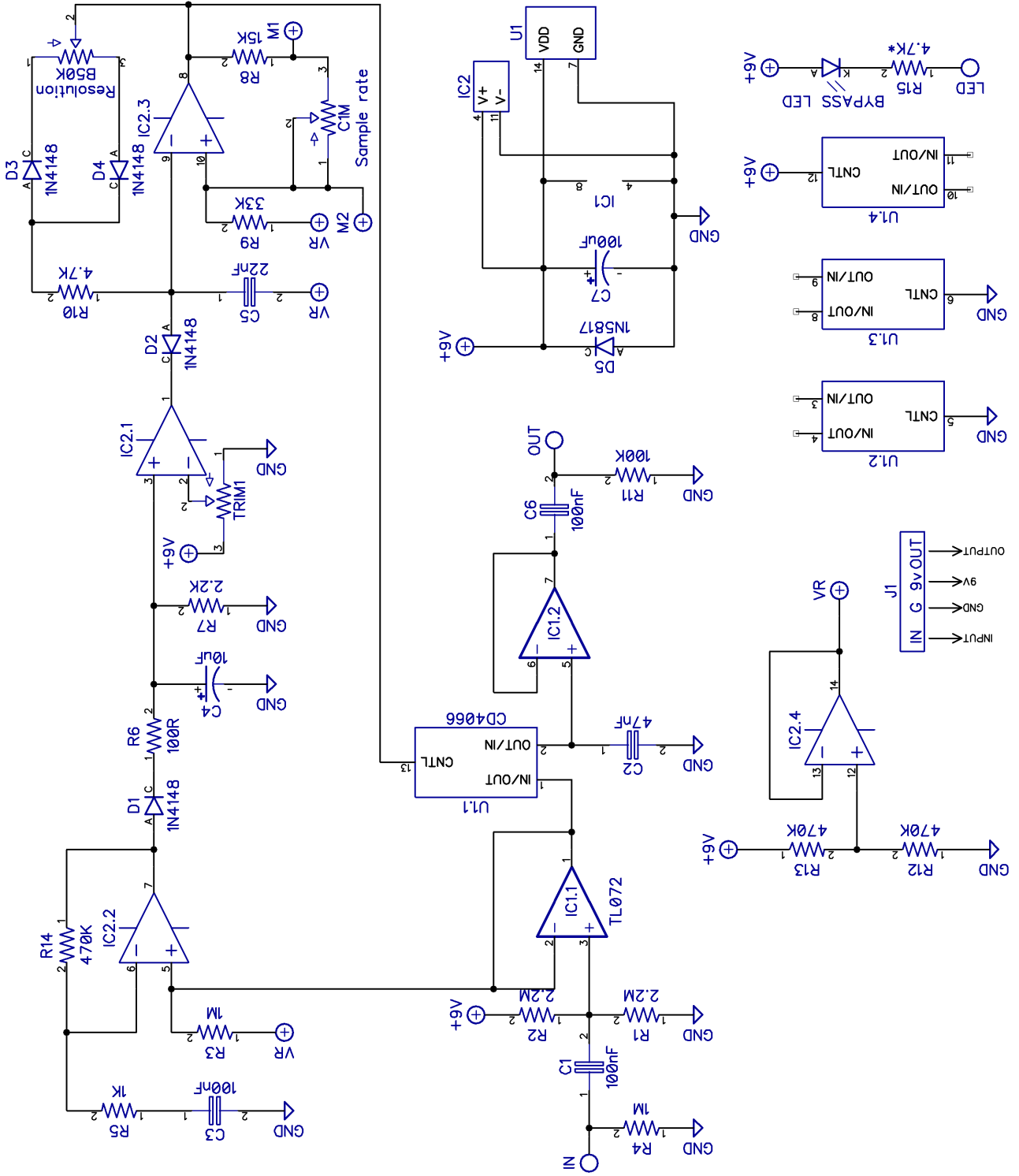

## **Troubleshooting**

There's always a chance of running into trouble. To minimize error, follow the BOM and general building tips carefully. Take your time and don't rush. Take a break now and then. Use good solder, and it helps to have a decent soldering station instead of a cheap iron.

If you are still having trouble, please visit the madbean forum Parasit Studio subforum section and ask for help there.

<http://www.madbeanpedals.com/forum/index.php?board=84.0>

If you have bought the Musikding kit and have received a faulty or missing component, please contact musikding directly.

<https://www.musikding.de/kontakt.php?lang=eng>

## **Terms of use**

PCB's from Parasit Studio are intended for DIY use only. Commercial resale is not allowed. It's meant for personal use, which means that it's not allowed to build a lot of pedals and sell them for profit to strangers using public forums and craigslist ads. However, it's totally ok to build a few pedals and sell to your friends and bandmates. After all, that's what this hobby is about. DIY or DIE!

[www.parasitstudio.se](http://www.parasitstudio.se)  
[parasitstudio@gmail.com](mailto:parasitstudio@gmail.com)