

RAYGUN YOUTH

Build Document last updated september 2017
for PCB version 1.0 and 1.1

The Raygun Youth Chaos Fuzz is a insane sounding fuzz based on the CD4046 Phase Locked Loop (PLL) chip.

A phase locked loop is basically an oscillator (VCO) that generates an output based on a external reference signal. In this case it's a guitar signal that the PLL tries to lock on to. I write "tries" since a guitar signal is very complex and has alot of overtones and harmonies, making perfect tracking near impossible without further filtering, thus creating very chaotic sounds. (EDIT. It is possible to get pretty decent tracking, as my 0415 Guitar Synth shows, but then you won't get these lovely chaotic sounds that only the Raygun Youth Fuzz can do...)

This circuit works best with high output pickups. It is a gated circuit by nature of the comparator that turns the signal into a squarewave. If you are using single coils and need more sustain, try a boost or compressor in front. To improve tracking, use your neck pickup with the tone rolled off. I find that the most interesting sounds is up high on the fretboard. Happy playing!

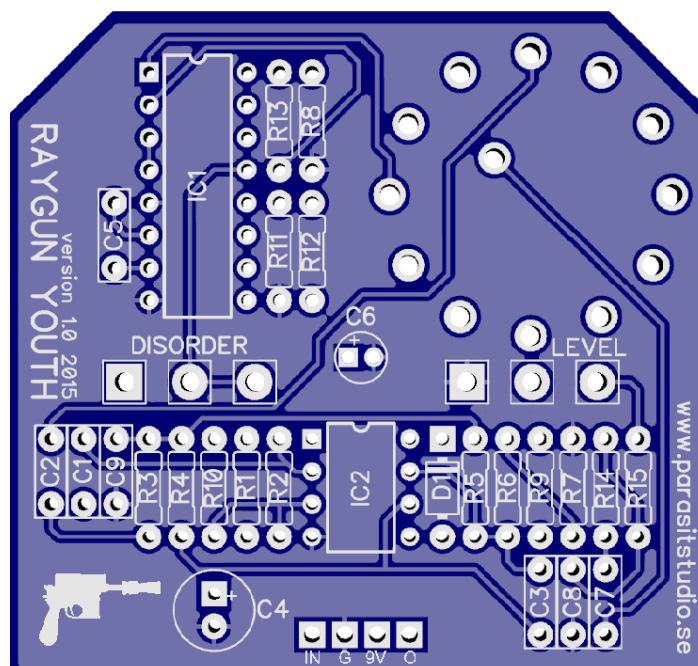

Controls

- **MODE switch:** Toggles between four different outputs
 - **STUN** - Straight squarewave fuzz, not effected by the disorder pot
 - **KILL** - Primary PLL output. Filtered to improve tracking
 - **DISINTEGRATE** - Secondary PLL output. Lacks filtering
 - **DEGENERATE** - Outputs the difference/interaction of the input signal and the VCO as the VCO tries to lock on the input
- **DISORDER:** Controls how quickly the VCO tracks to the input pitch
- **VOLUME:** Controls the overall volume

General builds tips

- Solder the low profile components first, from short to tall height. Recommended order: resistors, diodes, IC socket, film-caps, electrolytics, pots and switches
- CMOS chips are very sensitive to static charges and can be easily damaged. It's a good idea to wear a anti-static wristband or at least avoid wearing a wool jumper and petting your cat/dog while building...
- Always use sockets for IC chips and transistors to avoid heating them directly. It also makes it much easier to swap them out if needed.
- Pay special attention to the orientation of the diodes and electrolytics.
- All PCB's are designed for 16mm Alpha PCB mount angeled pots. You could also use solder lug type and just tack some "legs" with short pieces of wire to each pot to mimic a PCB mount type.
- The square pad represents pin 1 of each pot.
- The pots and the rotary switch are meant to be mounted on the bottom side (solder side) of the board, and soldered on the top (component side).

Raygun Youth Fuzz Bill Of Materials (BOM)

| Resistors | | Capacitors | | IC's | |
|-----------|------|---------------------|--------|----------------|---------------|
| R1 | 1M | C1 | 10nF | IC1 | CD4046BE |
| R2 | 1M | C2 | 100nF | IC2 | TL072 |
| R3 | 47K | C3 | 10nF | | |
| R4 | 4.7K | C4 | 47uF | | |
| R5 | 100K | C5 | 100nF | | |
| R6 | 10K | C6 | 1uF | | |
| R7 | 100K | C7 | 100nF | | |
| R8 | 100K | C8 | 4.7nF | | |
| R9 | 10K | C9 | 100nF | | |
| R10 | 10K | | | | |
| | | Diodes | | Potentiometers | |
| R11 | 10K | D1 | 1N4001 | Disorder | B500K |
| R12 | 100K | 1x LED (for bypass) | | Volume | B50K |
| R13 | 3.3K | | | | |
| R14 | 2.2K | | | Switches | |
| R15 | 100K | | | Mode | Rotary switch |
| R16** | 10K | | | | |
| CLR* | | | | | |

Suitable rotary switches:

- Alpha 3pole/4position (Alpha SR2612F-0304-21R0B-D8-N)
- Alpha 3pole/4position (Alpha SR2612F-0304-18R0B-D8-N)
- Cut off two of the middle pins of the rotary, which two doesn't matter since it's 3 identical sides to the switch and only 1/3 is used.
- Both PCB pin and solder lugs versions fit, but if using the solder lug version you will have to cut the pins shorter to fit through the holes.
- These are available at Tayda, Mouser, Banzai Music and Ebay.
<http://www.taydaelectronics.com/rotary-switch-3-pole-4-position-alpha-sr2612f.html>
- * Current Limiting Resistor for your on/off (bypass) LED. This will have to be wired off board. Use the appropriate value for your LED type. I suggest using a 4.7 resistor for normal diffused LEDs or a 15K resistor for a clear superbright LED.
- ** R16 is only used on the 1.1 version of the PCB
- **Also not included in the BOM but good to have: enclosure, input and output jacks, DC jack, LED Bezel, 3PDT switch and knobs.**

Wiring

For more info on how to wire up the stompswitch, jacks ect, please visit the Parasit Studio website and download the PDF called "offboard wiring". You can find it here:

<http://www.parasitstudio.se/build-docs.html>

Drilling template (1590B)

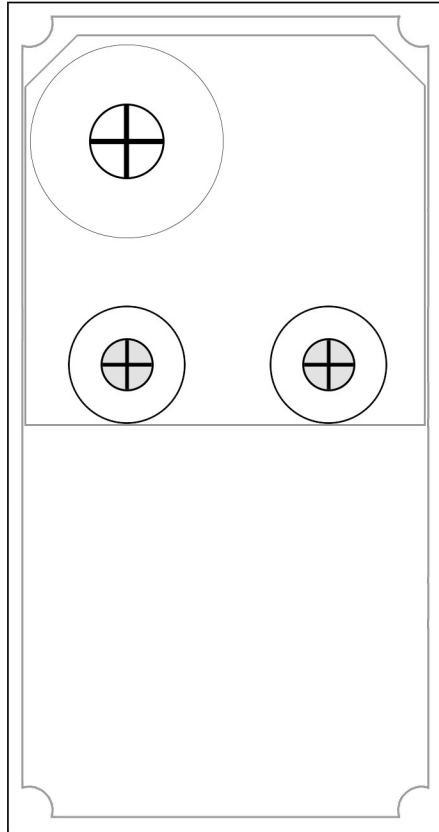

- Use at your own risk! This template is approximate.
- Make sure your printer isn't doing any scaling / is set to 100% print size.
- Drill footswitch, DC jack and input/output jacks to your own preference.
- Some PCB mount pots have longer shafts than others, it will change the hole positions slightly =
- **Measure and confirm before drilling!**

Schematic (ver. 1.0)

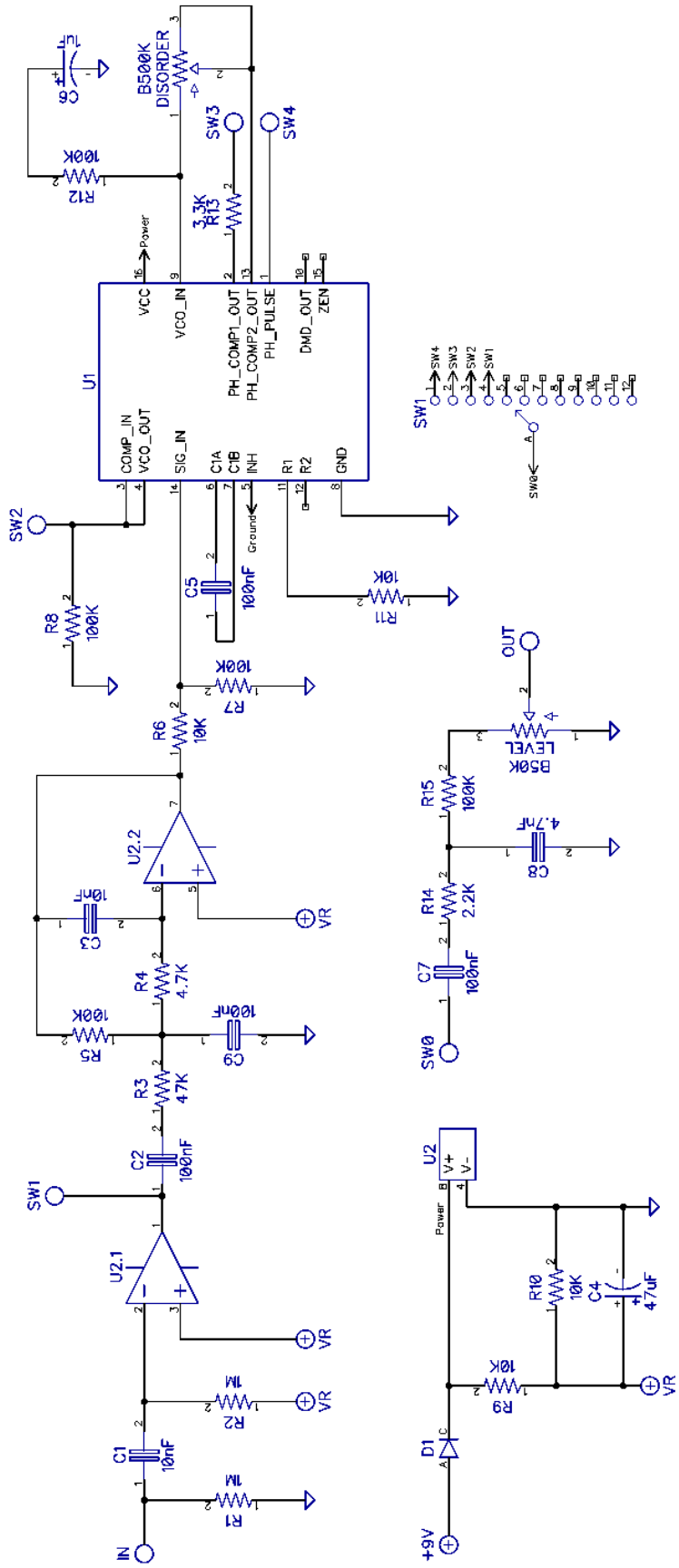

Optional CV input

With the 1.1 board, it's easy to add a Control Voltage input jack, so you can connect the Raygun Youth to an external LFO from a synthesizer or another pedal. To wire up the CV input jack, connect the CV in pad on the board to the tip of a jack (I prefer a 3.5mm jack, but it can be any type depending on which type of equipment that you want to interface with). Make sure the sleeve of the jack is connected to ground (it usually is through the enclosure, unless you use a isolated jack type). If you use a TRS/balanced jack, just leave the ring lug unconnected.

With the 1.0 board you can add the CV input by connecting the tip of the CV jack to Disorder pot lug 1 in series with a 10K resistor.

Troubleshooting

There's always a chance of running into trouble. To minimize error, follow the BOM and general building tips carefully. Take your time and don't rush. Take a break now and then. Use good solder, and it helps to have a decent soldering station instead of a cheap iron.

If you are still having trouble, please visit the madbean forum Parasit Studio subforum section and ask for help there.

<http://www.madbeanpedals.com/forum/index.php?board=84.0>

If you have bought the Musikding kit and have received a faulty or missing component, please contact musikding directly.

<https://www.musikding.de/kontakt.php?lang=eng>

Terms of use

PCB's from Parasit Studio are intended for DIY use only. Commercial resale is not allowed. It's meant for personal use, which means that it's not allowed to build a lot of pedals and sell them for profit to strangers using public forums and craigslist ads. However, it's totally ok to build a few pedals and sell to your friends and bandmates. After all, that's what this hobby is about. DIY or DIE!

www.parasitstudio.se
parasitstudio@gmail.com