

# THE ARCADIATOR

**Build Document last updated may 2016**  
for PCB version 2.0

*Please make sure you are using the right version build document for your PCB  
since there is a newer PCB version now available*

The Arcadiator is an insane 8-bit sounding fuzz. It does octave down (one or two octaves), alternating octaves, octave up and pulse width modulation.

The pulse width modulation signal blended with the octave down gives it a retro game'ish sound that brings backs memories of the 8-bit era of videogaming. With all switches down it can also do ear-ripping octave up fuzz.

This circuit works best with high output pickups. It is a gated circuit by nature of the CMOS logic. If you are using single coils and need more sustain, try a boost or compressor in front. To improve tracking of the octave down, use your neck pickup with the tone rolled off.

Happy playing!



## Changelog from version 1.1

- New PCB design
- Optimized circuit:
  - Improved sustain (one extra gainstage added)
  - Improved octave tracking
  - Trimmers replaced with fixed resistors
  - Some unnecessary parts removed
  - Improved LFO bypass
- Modfriendly:
  - Optional clean blend connections
  - Optional modboard connections

Read more about the optional mods at page 5.

## Controls

### SWITCHES

- **MODE:** Turns the octave down on/off. With the LFO engaged the mode switch changes between alternating octaves down or just octave down and unison. It can make a choppy "tremolo" of the octave down depending on how the blend pot is set.
- **LFO:** This turns the LFO/alternating octaves on/off
- **PWM:** This toggles between Pulse modulated signal or Octave up
- **OCTAVE:** This toggles between one or two octaves down

### POTENTIOMETERS

- **RATE:** Controls the rate of the LFO / alternating octaves modulation
- **WIDTH:** Controls the pulse width or the intensity of the octave up
- **BLEND:** Blends between PWM/Octave up and Octave down
- **VOLUME:** Controls the overall volume

## General builds tips

- Solder the low profile components first, from short to tall height. Recommended order: resistors, diodes, IC socket, film-caps, electrolytics, pots and switches
- CMOS chips are very sensitive to static charges and can be easily damaged. It's a good idea to wear an anti-static wristband or at least avoid wearing a wool jumper and petting your cat/dog while building...
- Always use sockets for IC chips and transistors to avoid heating them directly. It also makes it much easier to swap them out if needed.
- Pay special attention to the orientation of the diodes and electrolytics.
- The square pad represents pin 1 of each pot.
- **There are a LOT of switches and pots on this PCB. Be sure to place them in the PCB without soldering first, THEN place them in your drilled enclosure. Gently tighten the nuts to the enclosure, then solder LAST. Otherwise, it will be really hard to get this in your enclosure.**
- This PCB's is designed for 16mm Alpha PCB mounted angled pots. You could also use solder lug type and just tack some "legs" with short pieces of wire to each pot to mimic a PCB mount type. Again, it is a very good idea to drill holes in your enclosure first, and mount the pots with the nuts BEFORE soldering the pots to the PCB. This ensures you won't put a lot of stress on the PCB.
- **The A B C pads needs one link between A/B or B/C:**
  - Link A and B to build the standard configuration
  - Link B and C if you are doing the clean blend mod

## Wiring

For more info on how to wire up the stomp switch, jacks ect, please visit the Parasit Studio website and download the PDF called "offboard wiring". You can find it here:

<http://www.parasitstudio.se/build-docs.html>

## The Arcadiator 2.0 Bill Of Materials (BOM)

Resistors		Capacitors		IC's	
R1	1M	C1	100nF	IC1	CD4069UBE
R2	220K	C2	100pF	IC2	CD4024BE
R3	1M	C3	2.2nF	IC3	CD4070BE
R4	1M	C4	1uF		
R5	10K	C5	1uF		
R6	27K	C6	10nF	Potentiometers	
R7	100K	C7	100nF	BLEND	B500K
R8	47K	C8	100nF	WIDTH	C500K
R9	100K	C9	47nF	RATE	B250K
R10	100K	C10	100uF	VOLUME	A100K
R11	100K	C11	2.2uF**	(B50K)	optional clean blend pot
R12	100K				
R13	100K	Diodes		Switches	
R14	100K	D1	1N4148	OCTAVE	DPDT on/on
R15	10K	D2	1N4148	PWM	SPDT on/on
R16	68K	D3	1N4148	LFO	SPDT on/on
R17	47K	D4	1N4148	MODE	SPDT on/on
R18	100K	D5	1N5817		
R19	100K				
R20	4.7K*	1x LED			

- \* Current Limiting Resistor for the bypass/rate indicator LED. Use the appropriate value for your LED type.
- The board mounted LED works as both a bypass indicator and LFO rate indicator LED, as the LED only blinks when playing and stays lit otherwise when the pedal is engaged, and off when disengaged.
- The "LED" hole (next to the output connection hole) should be connected to the ground for LED bypass on your stomp switch (if not using the optional 3PDT board).
- \*\* C11 is only needed if doing the clean blend mod. **If not, do not include it!**
- Other things that are not included in the BOM but good to have: enclosure, input and output jacks, DC jack, stomp switch and knobs.

## OPTIONAL MODS

### “CLEAN” BLEND

**UPDATE 2016 nov: This mod contains an error in the 2.0 version PCB and should not be built according to the original instructions (greyed out text), but it can be added using the discription beflow.**

This mod is good for bassplayers. The clean signal is taken after the first gainstage so it's a little distorted and coloured, but it works fine with bass. I do not recommended this mod if you are going to use this pedal with a guitar only.

For this mod you need:

- One B50K potentiometer - Solder this offboard to the clean blend pads. The square pad represents lug 1 of the pot. Drill one extra hole somewhere in the enclosure for the pot. I recommend putting this pot at the side of the enclosure.
- Solder a link between the B and C pads on the PCB  
*See the general build tips notes about the A B C pads!*
- Include C11 (2.2uF)  
*If not you are not doing this mod, don't include this cap!  
(don't put a link there, just leave it out).*

If you still want to do the blend mod with the 2.0 version PCB, this is how you wire it up (omit the links between the pads):

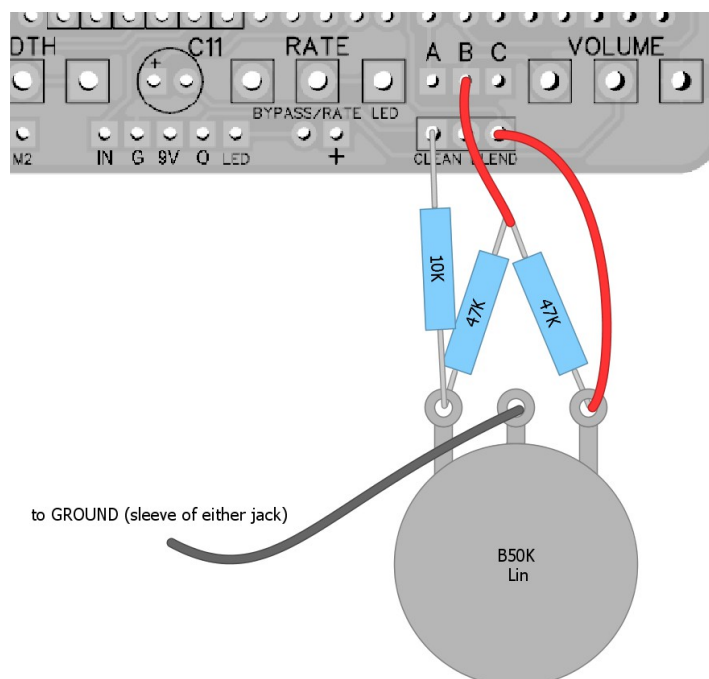

## **MODBOARD** (optional LFO daughterboard)

M1/M2 connections can be connected to the optional Modboard to modulate the Pulse Width (the width pot function).

For this mod you need:

- The Modboard daughterboard PCB with components
- One SPDT (on/on) switch

*Read more about it in the Modboard Build Document.*

## **Free running LFO mode**

Here's an easy mod. If you want to add another mode to the LFO switch, just use a SPDT on/off/on insted. In the middle position the LFO will be running all the time insted of being gated by the guitar signal.

*Just though i'd mention this mod since it's now possible with the 2.0 PCB. However, I don't recommend it since the free running mode will have a loud ticking (heard when not playing) and it also means that you will probably want to add another bypass LED.*

## Drilling template (1590BB)

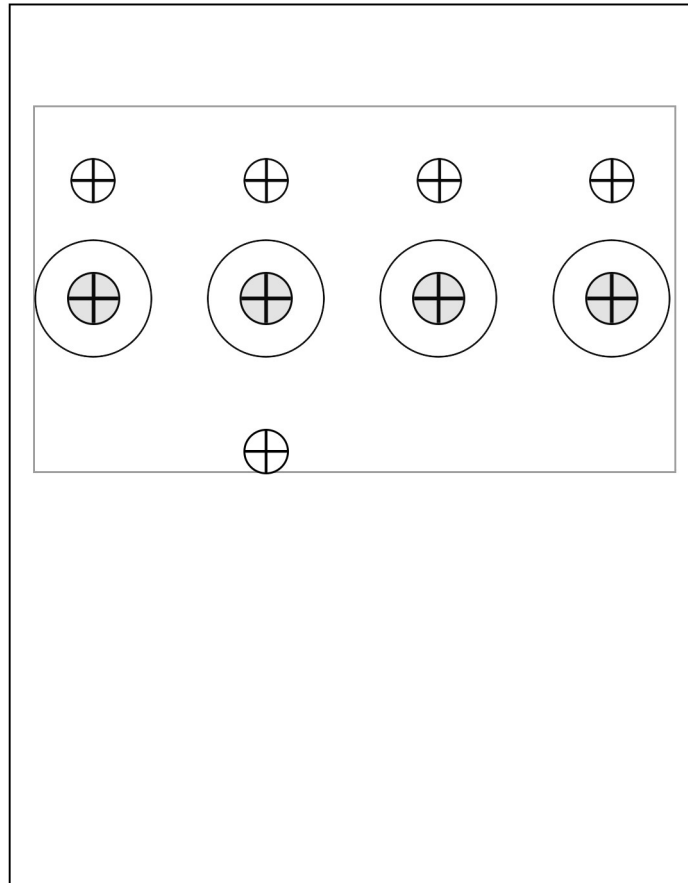

- Use at your own risk! This template is approximate.
- Make sure your printer isn't doing any scaling / is set to 100% print size.
- Drill footswitch, DC jack and input/output jacks to your own preference.
- **Measure and confirm before drilling!**
- Read the build tips section highlighted in red before soldering pots and switches to the PCB.

# Schematic

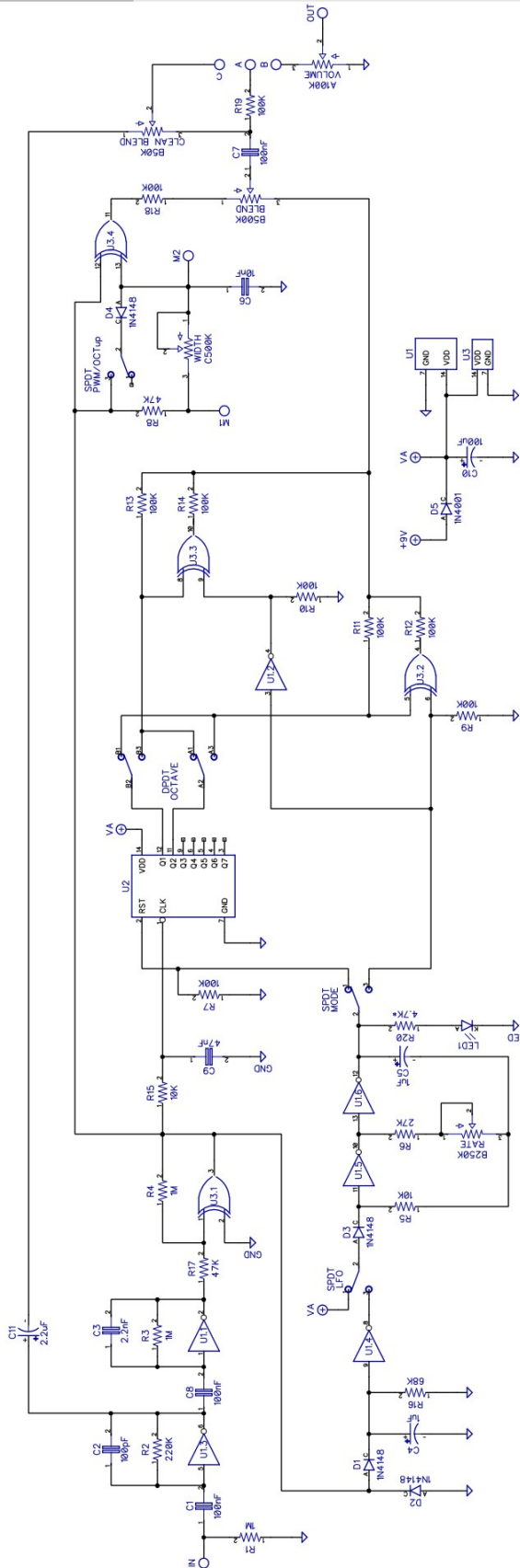



## **Troubleshooting**

There's always a chance of running into trouble. To minimize error, follow the BOM and general building tips carefully. Take your time and don't rush. Take a break now and then. Use good solder, and it helps to have a decent soldering station instead of a cheap iron.

If you are still having trouble, please visit the madbean forum Parasit Studio subforum section and ask for help there.

<http://www.madbeanpedals.com/forum/index.php?board=84.0>

If you have bought the Musikding kit and have received a faulty or missing component, please contact musikding directly.

<https://www.musikding.de/kontakt.php?lang=eng>

## **Terms of use**

PCB's from Parasit Studio are intended for DIY use only. Commercial resale is not allowed. It's meant for personal use, which means that it's not allowed to build a lot of pedals and sell them for profit to strangers using public forums and craigslist ads. However, it's totally ok to build a few pedals and sell to your friends and bandmates. After all, that's what this hobby is about. DIY or DIE!

[www.parasitstudio.se](http://www.parasitstudio.se)  
**parasitstudio@gmail.com**