

# 1985 GUITAR SYNTHESIZER

**Build Document last updated december 2018**

Version 1.0 2018

The 1985 Guitar Synth is a Attiny85 microcontroller-based square wave guitar synth/fuzz with both octave down, octave up and detuned modes. The octave up oscillator is based on a frequency counter and sounds super glitchy, like a malfunctioning R2-D2... The octave down oscillator is much more controlled. This is the first Parasit Studio DIY project that is fully digital and that allowed for adding a fun hidden feature aswell... :-)

Happy building and playing!

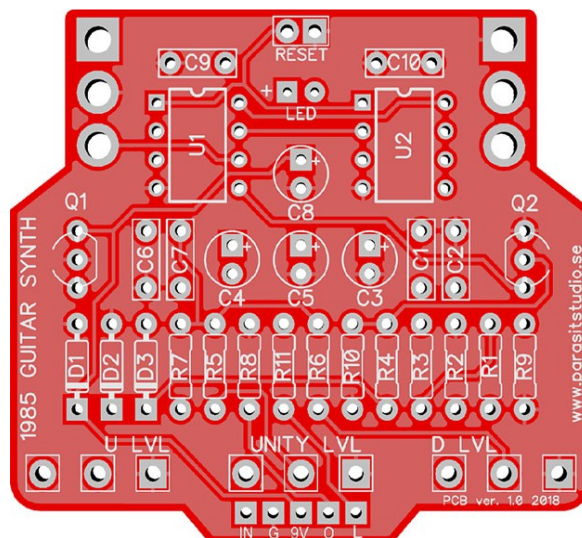

## PLEASE NOTE!

*This project requires programming. You can get pre-programmed chips together with the PCB from the Parasit Studio webshop or included with the Musikding kit. You can also program your own Attiny85 chips if you know how and have the required interface and software. You can find the HEX files needed at [www.parasitstudio.se](http://www.parasitstudio.se)*

## CONTROLS

### POTENTIOMETERS

- DOWN – The level of the octave down
- UNISON – The level of the unison square wave
- UP – The level of the octave up

*The unison is the direct fuzz which works well with chords. This is unaffected by the other controls.*

### SWITCHES

- OCTAVE DOWN - toggle between:
  - One octave down
  - Detuned (in between one and two octaves down)
  - Two octaves down

*The detune is the input signal divided by 3.*

- OCTAVE UP – toggles the saw:
  - One octave up
  - Detuned (in between one and two octaves up)
  - Unison (with a slight detune)

*The one octave up mode is very glitchy and won't stay in tune for the entire fretboard, but that's part of the fun... The Unison mode is slightly detuned to give you a layered and phasey sound when blended with the direct fuzz.*

## **General builds tips**

- Solder the low profile components first, from short to tall height. Recommended order: resistors, diodes, IC socket, film-caps, electrolytics, pots and switches
- IC chips are sensitive to static charges and can be easily damaged. It's a good idea to wear an anti-static wristband or at least avoid wearing a wool jumper and petting your cat/dog while building...
- Always use sockets for IC chips and transistors to avoid heating them directly. It also makes it much easier to swap them out if needed.
- Pay special attention to the orientation of the IC's, diodes and electrolytics.
- The square pad represents pin 1 of the pot.
- This PCB's is designed for 16mm Alpha PCB mounted angled pots. You could also use solder lug type and just tack some "legs" with short pieces of wire to the pot to mimic a PCB mount type.
- Mount the pots and the switches to the back side (solder side) of the PCB and solder them from the front side (component side).
- Cover the back of the pots (with pot covers or tape or a piece of carbon) so that they don't create a short on the PCB.

## **Wiring**

For more info on how to wire up the stomp switch, jacks ect, please visit the Parasit Studio website and download the PDF called "offboard wiring". You can find it here:

<http://www.parasitstudio.se/build-docs.html>

## 1985 Guitar Synth Bill Of Materials (BOM)

Resistors		Capacitors		IC's	
R1	10K	C1	100nF	U1	Attiny85 20PU
R2	1M	C2	10nF	U2	Attiny85 20PU
R3	470K	C3	22uF	<b>Potentiometers</b>	
R4	10K	C4	2.2uF		
R5	100K	C5	1uF	OCTAVE DOWN	A100K
R6	100K	C6	1nF	UNISON	A100K
R7	100K	C7	100nF	OCTAVE UP	A100K
R8	100K	C8	22uF	<b>Switches</b>	
R9	10K	C9	100nF		
R10	4.7K	C10	100nF	DOWN	SPDT on/off/on
R11	CLR*			UP	SPDT on/off/on
<b>Diodes</b>				RESET	Momentary SPST **
D1	1N4001			<b>Transistor(s)</b>	
D2	1N4148			Q1	78L05
D3	1N4148			Q2	2N3904
1x LED					

### BOM NOTES

- Use multilayer ceramic capacitors for C9 & C10 (important!)
- \* R11 is a Current Limiting Resistor for the bypass LED. Use the appropriate value for your LED type. For diffused LED's I recommend using a 4.7K resistor, and for clear superbright LED's I recommend a 15K resistor.
- \*\* The reset switch is optional and not really needed. It will reset the pedal which will restart the hidden feature (depending on the other switches). Use a momentary normally open switch.

**Other things not included in the BOM but good to have:** enclosure, input and output jacks, DC jack, led bezels, 3PDT switch and knobs.

## Drilling template (1590B)

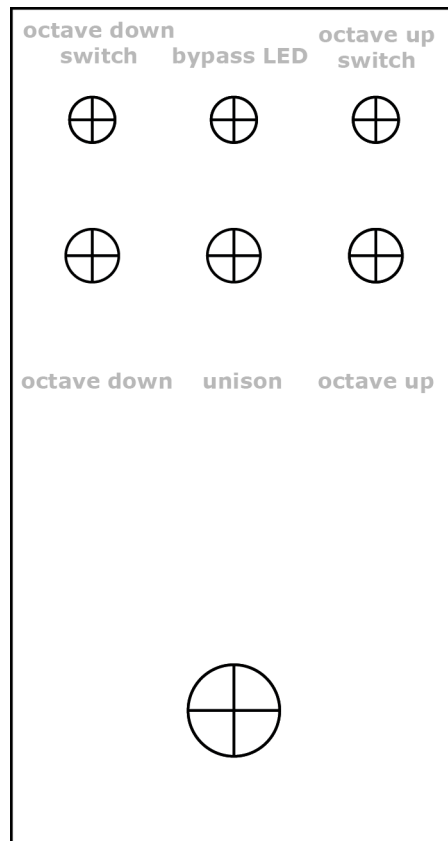

- This template is approximate. Use at your own risk!
- Make sure your printer isn't doing any scaling / is set to 100% print size.
- Drill the DC jack and input/output jacks (and the optional reset switch) to your own preference.
- The LED hole here is 6mm, for using a 3mm LED with a bezel.
- **Measure and confirm before drilling!**

# Schematic

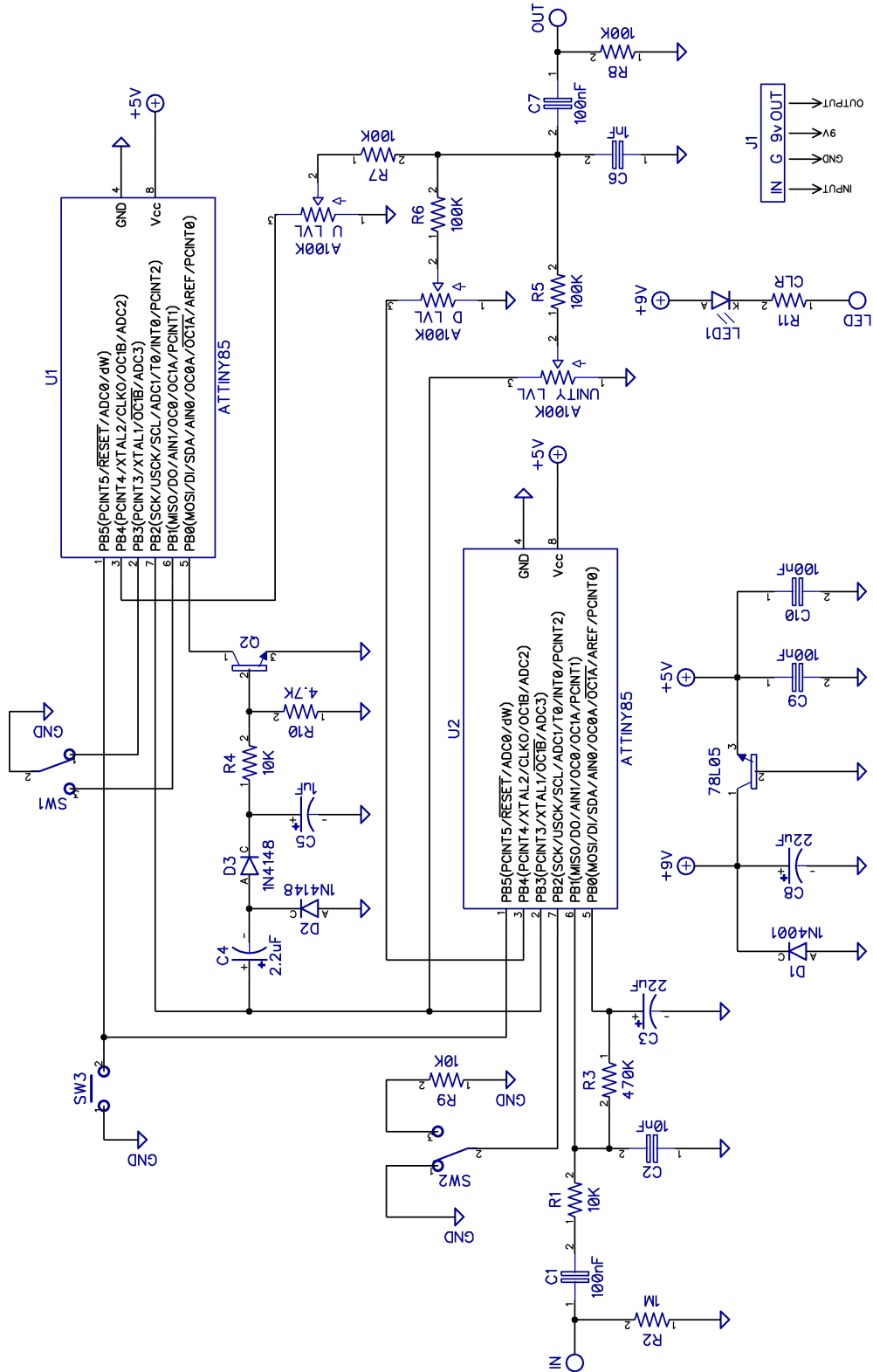

## **Troubleshooting**

There's always a chance of running into trouble. To minimize error, follow the BOM and general building tips carefully. Take your time and don't rush. Take a break now and then. Use good solder, and it helps to have a decent soldering station instead of a cheap iron.

If you are still having trouble, please visit the madbean forum Parasit Studio subforum section and ask for help there.

<http://www.madbeanpedals.com/forum/index.php?board=84.0>

If you have bought the Musikding kit and have received a faulty or missing component, please contact musikding directly.

<https://www.musikding.de/kontakt.php?lang=eng>

## **Terms of use**

PCB's from Parasit Studio are intended for DIY use only. Commercial resale is not allowed. It's meant for personal use only, which means that it's not allowed to build a lot of pedals and sell them for profit to strangers using public forums and craigslist ads. However, it's totally ok to build a few pedals and sell to your friends and bandmates. After all, that's what this hobby is about. DIY or DIE!

[www.parasitstudio.se](http://www.parasitstudio.se)  
**parasitstudio@gmail.com**