

0415 GUITAR SYNTH

Build Document last updated may 2020

for PCB version 2.0

The 0415 Guitar Synth is a fun a simple pedal that transforms the signal into a square wave, up to four octaves apart: one or two octaves up can be mixed with one or two octaves down for super synthy sounds.

This circuit works best with high output pickups (although I had decent results with single coils aswell). It is a gated circuit by nature of the schmitt trigger that turns the signal into a squarewave. If you are using single coils and need more sustain, try a boost or compressor in front. To tighten up the octave tracking, use your neck pickup with the tone rolled off.

Happy playing!

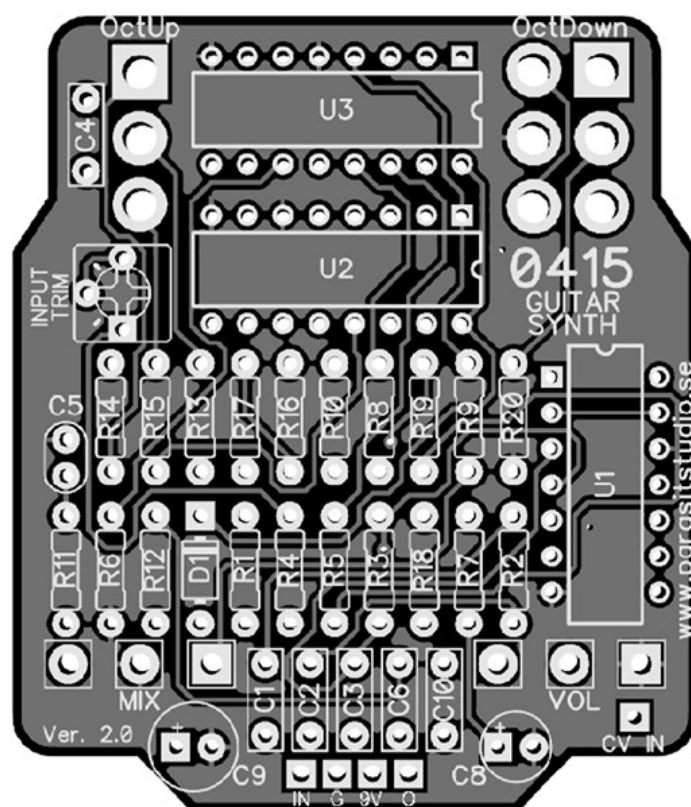

Update 2020-05-14

It's come to my attention that several people has been trouble getting the **octave up switch** working recently.

The PCB has been verified and built succesfully by many many people, but this sudden trouble with the octave up may be caused by a manufacturing issue on the latest run of boards.

Lucky, there's a simple fix to get it working. :)

- Omit/remove R14 and R15 from the PCB and put links there instead (you can use a cutoff component leg)
- Omit/remove R13 from the PCB aswell – but don't put a link there.
- Solder a short link between the (now empty) top hole for R13 to the top hole/leg of R17 (the resistor next to R13, to the right).

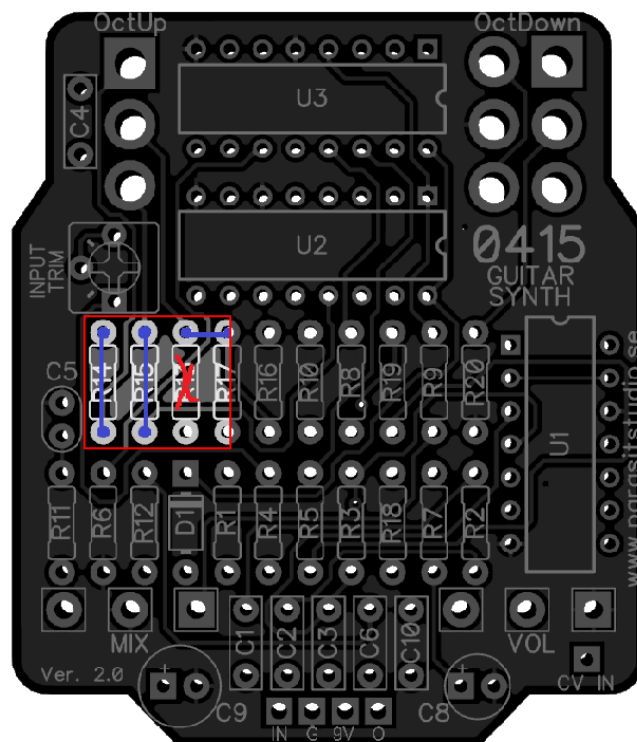

Even if this shows an unpopulated board, all other components except R13, R14 and R15 should be installed as normal. The blue lines are the 3 links that needs to be soldered in.

Changelog version 2.0

- CV input added
- Tracking slightly improved
- Both switches changed to on/off/on types for two new features:
 - Octave down switch middle position: Fundamental note
 - Octave up switch middle position: Detuned upper octave

Controls

- SWITCHES:
 - OctDown – Toggles between one octave down, fundamental note, or two octaves down
 - OctUp – Toggles between one octave up, a detuned mode (in between one and two octaves), or two octaves up
- MIX: Blends between octave down and octave up
- VOLUME: Controls the overall volume

General builds tips

- Solder the low profile components first, from short to tall height. Recommended order: resistors, diodes, IC socket, film-caps, electrolytics, pots and switches
- CMOS chips are very sensitive to static charges and can be easily damaged. It's a good idea to wear an anti-static wristband or at least avoid wearing a wool jumper and petting your cat/dog while building...
- Always use sockets for IC chips and transistors to avoid heating them directly. It also makes it much easier to swap them out if needed.
- Pay special attention to the orientation of the diodes and electrolytics.
- All PCB's are designed for 16mm Alpha PCB mount angled pots. You could also use solder lug type and just tack some "legs" with short pieces of wire to each pot to mimic a PCB mount type.
- The square pad represents pin 1 of each pot.
- Both pots and switches are meant to be mounted on the backside (the solder side) of the PCB and soldered from the front side (component side).

Bill Of Materials (BOM)

Resistors				IC's	
R1	1M	R16	10K	IC1	CD4069UBE
R2	1M	R17	10K	IC2	CD4015BE
R3	1M	R18	47K	IC3	CD4046BE
R4	1M	R19	47K		
R5	10K	R20	100K		
		Capacitors		Potentiometers	
R6	10K	C1	100nF	MIX	B50K
R7	10K	C2	4.7nF	VOLUME	A100K
R8	4.7K	C3	100nF	TRIMPOT	200K
R9	100K	C4	33nF	Switches	
R10	100K	C5	470pF	OctDown	DPDT on/off/on
R11	47K	C6	100nF	OctUp	SPDT on/off/on
R12	47K	C7	-	Diodes	
R13	10K**	C8	2.2uF	D1	1N4001
R14	10K**	C9	100uF	on/off LED x1	
R15	10K**	C10	2.2nF	+ 1x CLR*	

- ** = see page two!
- The trimmer sets the input sensitivity, from very sensitive and noisy when just touching the strings to more gated and controlled. Adjust to suite your guitar output and taste.
- * = Current limiting resistor for the LED. This needs to be wired offboard or on a 3PDT board. Choose the appropriate value for the type of LED you are using. A 4.7K resistor is usually a good value for a regular diffused LED and 15K resistor for a superbright clear LED.
- **Other things that are not included in the BOM but good to have: enclosure, input and output jacks, DC jack, 3PDT switch, LED bezel and knobs.**

Wiring

For more info on how to wire up the stompswitch, jacks ect, please visit the Parasit Studio website and download the PDF called "offboard wiring". You can find it here:

<http://www.parasitstudio.se/build-docs.html>

CV input (optional)

The CV input lets you hook up an external Low Frequency Square Wave Oscillator (LFO) that will modulate the upper octave for crazy sounds. The CV input can also trigger the PLL chip synthesis, so you can use it as a noise maker without any guitar connected to the input.

It works well with a wide range of voltages, so try connecting the LFO output from a synthesizer, modular system or the Parasit Studio New Wave CV Generator.

CV jack Wiring

To hook up the CV (control voltage) input jack, connect the CV pad on the PCB to the tip of a 3.5mm jack (or jack of your choice). Make sure that the sleeve of your jack is connected to ground (it usually is connected to ground via the enclosure unless you have an isolated jack type). If you use a stereo/balanced jack, just leave the ring lug unconnected.

Drilling template (1590B)

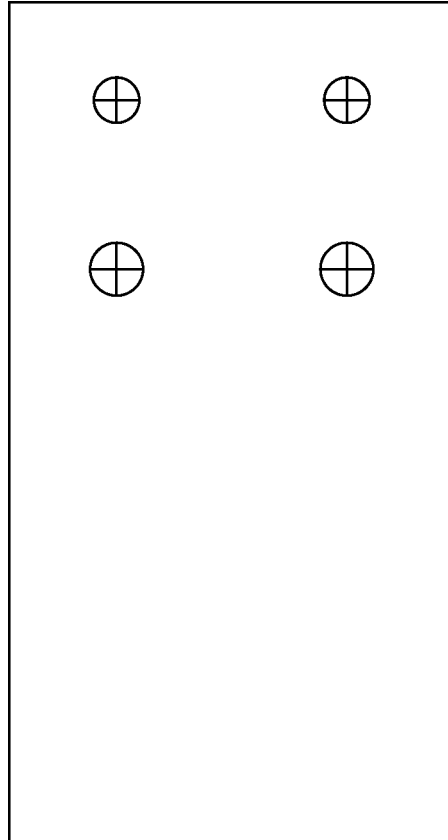

- Use at your own risk! This template is approximate.
- Make sure your printer isn't doing any scaling / is set to 100% print size.
- Drill footswitch, DC jack and input/output jacks to your own preference.
- **Measure and confirm before drilling!**

Schematic

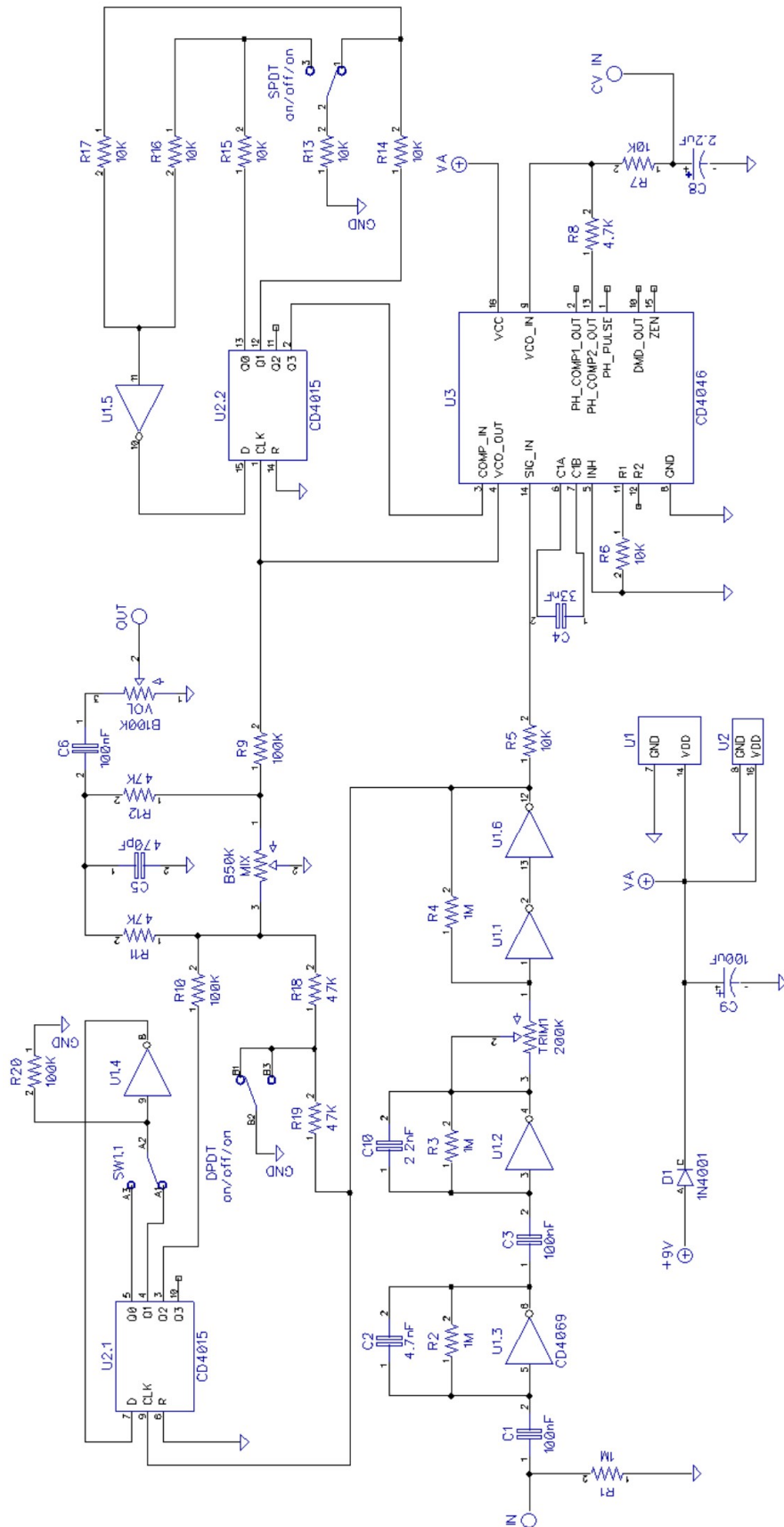

Troubleshooting

There's always a chance of running into trouble. To minimize error, follow the BOM and general building tips carefully. Take your time and don't rush. Take a break now and then. Use good solder, and it helps to have a decent soldering station instead of a cheap iron.

If you are still having trouble, please visit the madbean forum Parasit Studio subforum section and ask for help there.

<http://www.madbeanpedals.com/forum/index.php?board=84.0>

If you have bought the Musikding kit and have received a faulty or missing component, please contact musikding directly.

<https://www.musikding.de/kontakt.php?lang=eng>

Terms of use

PCB's from Parasit Studio are intended for DIY use only. Commercial resale is not allowed. It's meant for personal use, which means that it's not allowed to build a lot of pedals and sell them for profit to strangers using public forums and craigslist ads. However, it's totally ok to build a few pedals and sell to your friends and bandmates. After all, that's what this hobby is about. DIY or DIE!

www.parasitstudio.se
parasitstudio@gmail.com