

LIBERATION FREQUENCY FUZZ

Build Document last updated april 2024

Version 1.0 2024

The Liberation Frequency Fuzz is a analog square wave fuzz with a tunable and tracking monophonic oscillator that can be tuned from about one octave down to one octave up and anywhere in between. It also has a fun warp feature that uses a PLL output to create interesting sounds to the oscillator even when it's "out of tune".

This pedal works best with high output pickups. It is a gated fuzz. If you are using single coils and need more sustain, try a boost or compressor in front. To improve tracking of the oscillator, use the neck pickup on your guitar and play single notes closer to the 12th fret.

Have fun building and playing with the Liberation Frequency Fuzz!



Prototype build

The Liberation Frequency Fuzz is named after the song by the band Refused where my brother Dennis is the singer. We want the airwaves back!

Power

Input voltage - 9V DC

Current draw - 13mA

Controls

Level – overall volume

Blend – blends between fuzz and the oscillator

Tune – tunes the oscillator

Oct switch – switches range for the oscillator by one octave

Warp switch – enables the warped PLL output

Gate (pcb trimpot) – adjusts how gated / touch sensitive the fuzz is

The populated PCB

Here's a 3D render approximation of what the fully populated board should look like (except that the IC's should be in sockets).

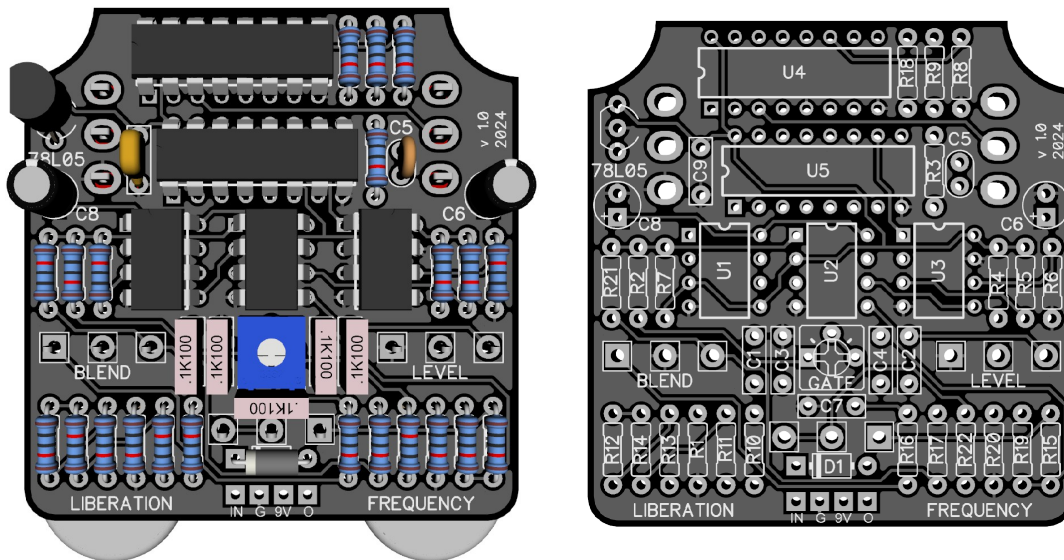

The PCB measures 52mm wide x 54mm tall

General building tips

- Just follow the Bill of Materials and solder the low profile components first.

Recommended order: resistors and diodes, chip sockets, trim pot, multilayer and ceramic capacitors, film box capacitors, transistors/voltage regulators, electrolytic capacitors, pots and switches, offboard wiring (jacks). Bend the legs of the components a little bit to prevent them from falling out, or use tape to hold them in place while soldering.

- Pay special attention to the orientation of the LED's, diodes, voltage regulator (78L05) and the electrolytic capacitors.
- Always use sockets for IC chips to avoid heating them directly. It also makes it much easier to swap them out if needed. The voltage regulator does not need to be socketed.
- CMOS chips are very sensitive to static charges and can be easily damaged. It's a good idea to wear an anti-static wristband. Or at least don't wear a woolen jumper and pat your dog while building, and keep the circuit away from rugs...
- Insert the chips into the sockets as the last thing you do when everything else is soldered into place.
- Break off the small tab on the potentiometers, so they can sit flush against the top cover.
- Make sure that the backside of your pots are covered so they don't short anything on the PCB. If you don't have pot covers I recommend PVC electrical tape.
- When it's time to solder the potentiometers, switches and buttons I recommend having the enclosure/lid prepared to make sure that they line up with the holes.

I recommend that you solder only the middle pin of each potentiometer to the PCB (so that the placement matches the silkscreen on the PCB and the pot stays in place when you turn the PCB around but still has some wiggle room). Screw in the switches in the enclosure and then put the PCB with the pots into the enclosure so that everything fits and finally solder the rest of the pot pins and the switches from the component side of the PCB.

Liberation Frequency Fuzz BOM (Bill of Materials)

Resistors				IC's	
R1	1M	R19	100K	U1	TL072
R2	1M	R20	100K	U2	LM393
R3	330K	R21	100K	U3	AD5220 **
R4	1K	R22	100K	U4	CD4046(BE)
R5	1K	CLR	4.7K	U5	CD4040(BE)
R6	1K	Capacitors		Transistors ect.	
R7	10K	C1	100nF	Q1	78L05
R8	10K	C2	100nF		
R9	10K	C3	47nF		
R10	33K	C4	1nF	Potentiometers	
R11	470K	C5	100pF	LEVEL	A100K
R12	470K	C6	1uF	BLEND	B50K
R13	47K	C7	2.2nF	TUNE	B100K
R14	47K	C8	47uF	GATE (trimpot)	50K
R15	47K	C9 *	100nF		
R16	47K	Diodes		Switches	
R17	47K	D1	1N5817	OCTAVE	SPDT on/on
R18	100K	1x LED	(bypass)	WARP	SPDT on/on

BOM Notes

- * = should be a multilayer ceramic capacitor (yellow capacitor)
- ** = AD5220BNZ100 - 100K DIP version of the IC

A good alternative to the AD5220 is the DS1804-100+.

It's a pin compatible IC, but it has 100 steps instead of 128, so the tuning of the oscillator will respond slightly differently and you may notice more stepping when tuning the oscillator.

- CLR is the current limiting resistor for the bypass LED (mounted on the 3PDT daughterboard or off board if you don't have the daughterboard).
- Things that are not included in the BOM list: enclosure, input and output jacks, DC jack, 3PDT stomp switch, led bezel and knobs.

Drill Template (1590B)

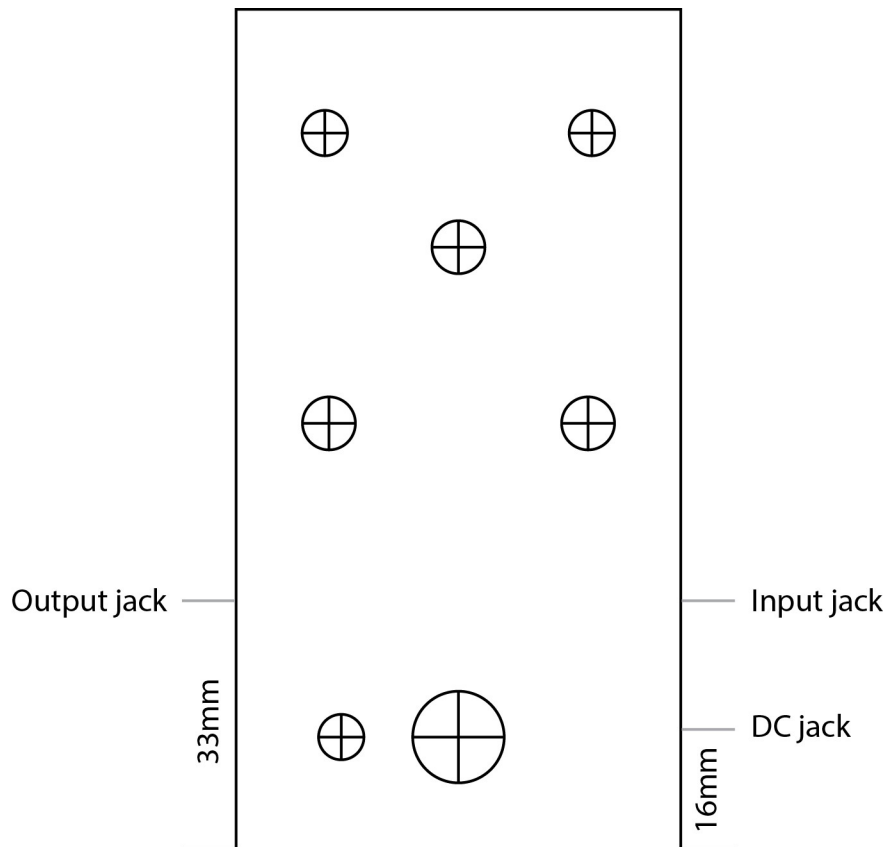

- Use at your own risk! This template is approximate.
- Make sure your printer isn't doing any scaling (100% print size).
- Jacks are measured from the edge at the front/top of the enclosure (as they were drilled on the prototype), but you can drill the positions for the footswitch, DC jack and input/output jacks to your own preference.
- The distance between the 3PDT switch and the LED is 15mm
- Typical drill sizes are:
 - switches / LED bezel (for a 3mm LED) - 6mm
 - potentiometers - 7mm
 - DC jack / 3PDT footswitch - 12mm (8mm for lumberg style DC jacks)
 - input/output jacks (Neutrik style) - 9,5mm (9mm for Lumberg style jacks)

Measure and confirm before drilling!

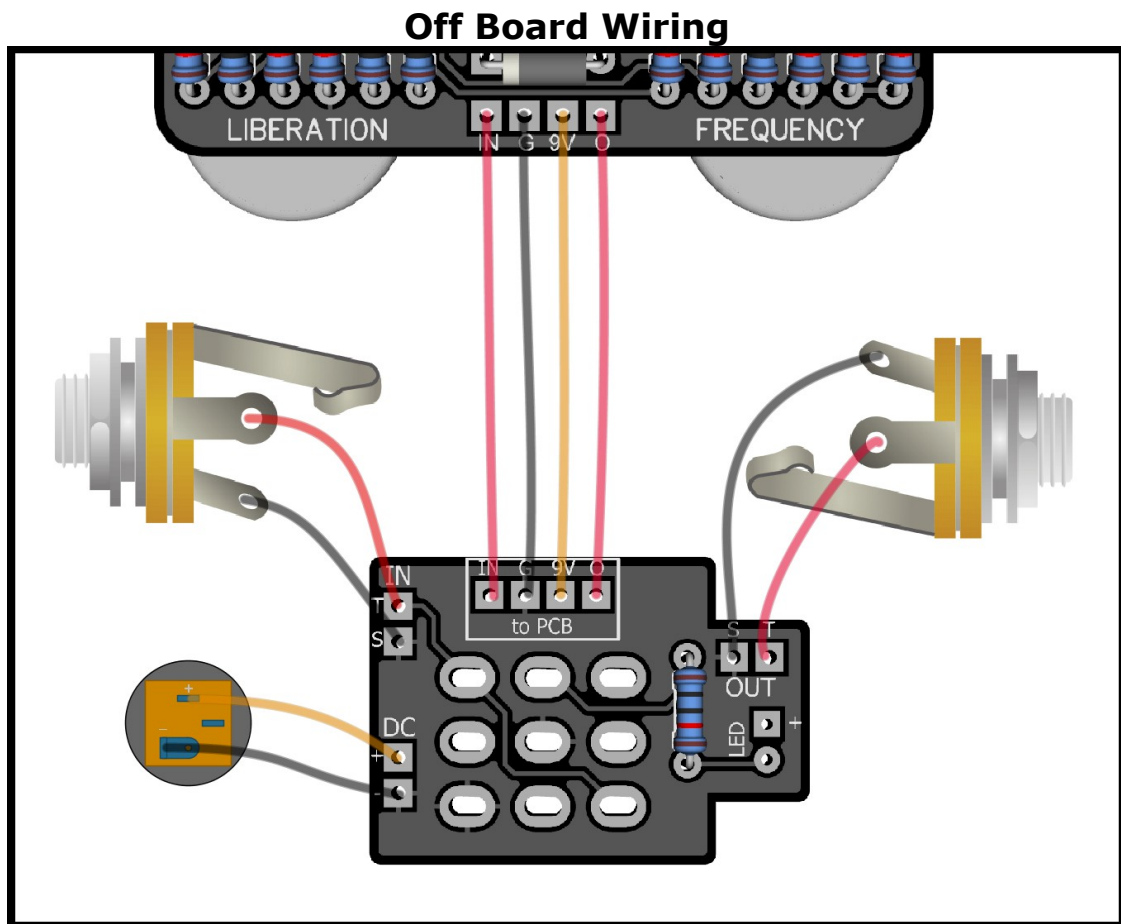

The top row of connections on the 3DPT daughterboard connects directly across to the main PCB as shown.

Input jack sleeve → "S" IN pad
 the lug that connects with the inner ring of the jack
 Input jack tip → "T" IN pad
 the lug that connects to the bracket on the jack

Output jack sleeve → "S" OUT pad
 the lug that connects with the inner ring of the jack
 Output jack tip → "T" OUT pad
 the lug that connects to the bracket on the jack

DC jack negative → "-" DC pad
 the widest lug, or the short lug if using a Lumberg style jack
 DC jack positive → "+" DC pad
 the outer lug if it's a 3 pin DC connector, or the long lug if using a Lumberg style jack

If you are not using the 3DPT daughterboard PCB, have a look at the offboard wiring diagram here (fig1/3): wiringrev3.pdf (parasitstudio.se)

Troubleshooting

There's always a chance of running into trouble. To minimize error, follow the BOM and general building tips carefully. Take your time and don't rush. Take a break now and then. Use good solder, and it helps to have a decent soldering station instead of a cheap iron.

If you are still having trouble, please visit the madbean forum Parasit Studio subforum section and ask for help there.

<http://www.madbeanpedals.com/forum/index.php?board=84.0>

If you have bought the Musikding kit and have received a faulty or missing component, please contact musikding directly.

<https://www.musikding.de/kontakt.php?lang=eng>

Terms of use

PCB's from Parasit Studio are intended for DIY use only. Commercial resale is not allowed. It's meant for personal use only, which means that it's not allowed to build a lot of pedals and sell them for profit to strangers using public forums and craigslist ads ect. However, it's totally ok to build a few pedals and give to your friends and bandmates. After all, that's what this hobby is about. :)

www.parasitstudio.se
parasitstudio@gmail.com